

ID	Service parts	S-RS	Description
A-01	6.429.076.001	DT	Cover USB/UTP
A-02	6.231.044.001	S	Service key
A-03	6.429.040.001	S	Cover print Bolero 1/2
A-04	6.429.135.001	DT	Mounting plate door switch
A-05	6.429.136.001	DT	Spring door contact switch
A-06	6.004.001.098	RS	Micro switch door
A-07	6.429.164.000	RS	HMI board + display
A-08	6.429.038.001	S	Bracket HMI board Bolero 1/2
A-09	6.014.004.052	S	Lock incl. key
A-10	6.014.012.017	S	Key
A-11a	6.429.167.000	S	Door Bolero 1/2 (assy)
A-11b	6.429.168.000	S	Door Bolero 1/2 without hot water tap (assy)
A-12	6.429.034.000	DT	Frame coffee outlet

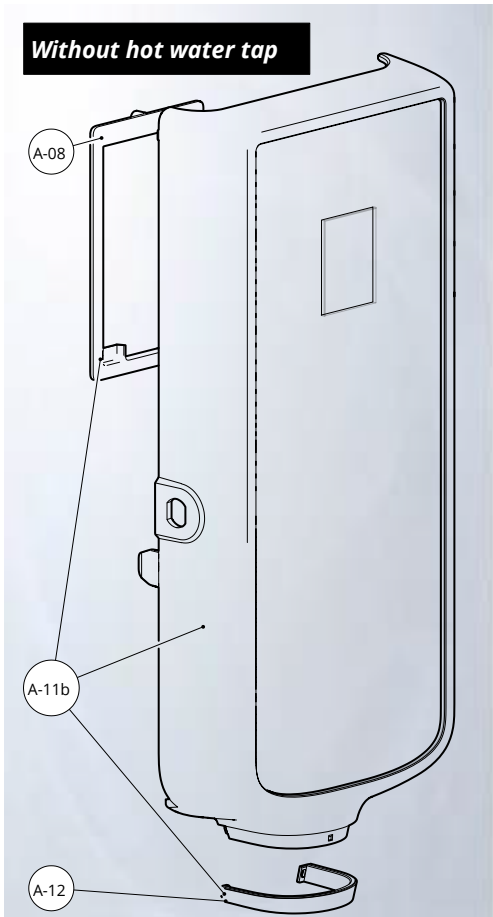

ID	Service parts	S-RS	Description
B-01	6.429.029.001	S	Lid
B-02	6.429.031.001	DT	Holder Lid
B-03	6.331.550.001	DT	Bracket powerboard
B-04	6.429.174.000	RS	Mainboard I/O 230V
B-05	6.004.001.089	RS	Micro switch
B-06	6.429.095.001	DT	Cover cord inlet
B-07a	6.006.001.101	S	Cord inlet with pull relief
B-07b	6.006.001.109	S	Cord inlet with pull relief (GB)
B-08a	6.003.012.060	S	Connection cord 3x1 mm
B-08b	6.003.012.118	S	Connection cord 3x1.5 mm (GB)
B-09	6.429.149.001	S	Hinge
B-10	6.231.204.001	S	Vibration damper
B-11	6.331.099.001	S	Grid fan
B-12	6.231.194.001	S	Rotor fan
B-13	6.000.229.146	RS	Ventilator motor
B-14	6.271.037.000	RS	Interface/MDB print
B-15	6.229.116.001	S	Float drip-tray
B-16	6.429.087.001	S	Foot extension
B-17	6.329.060.001	S	Foot 60x16xx8

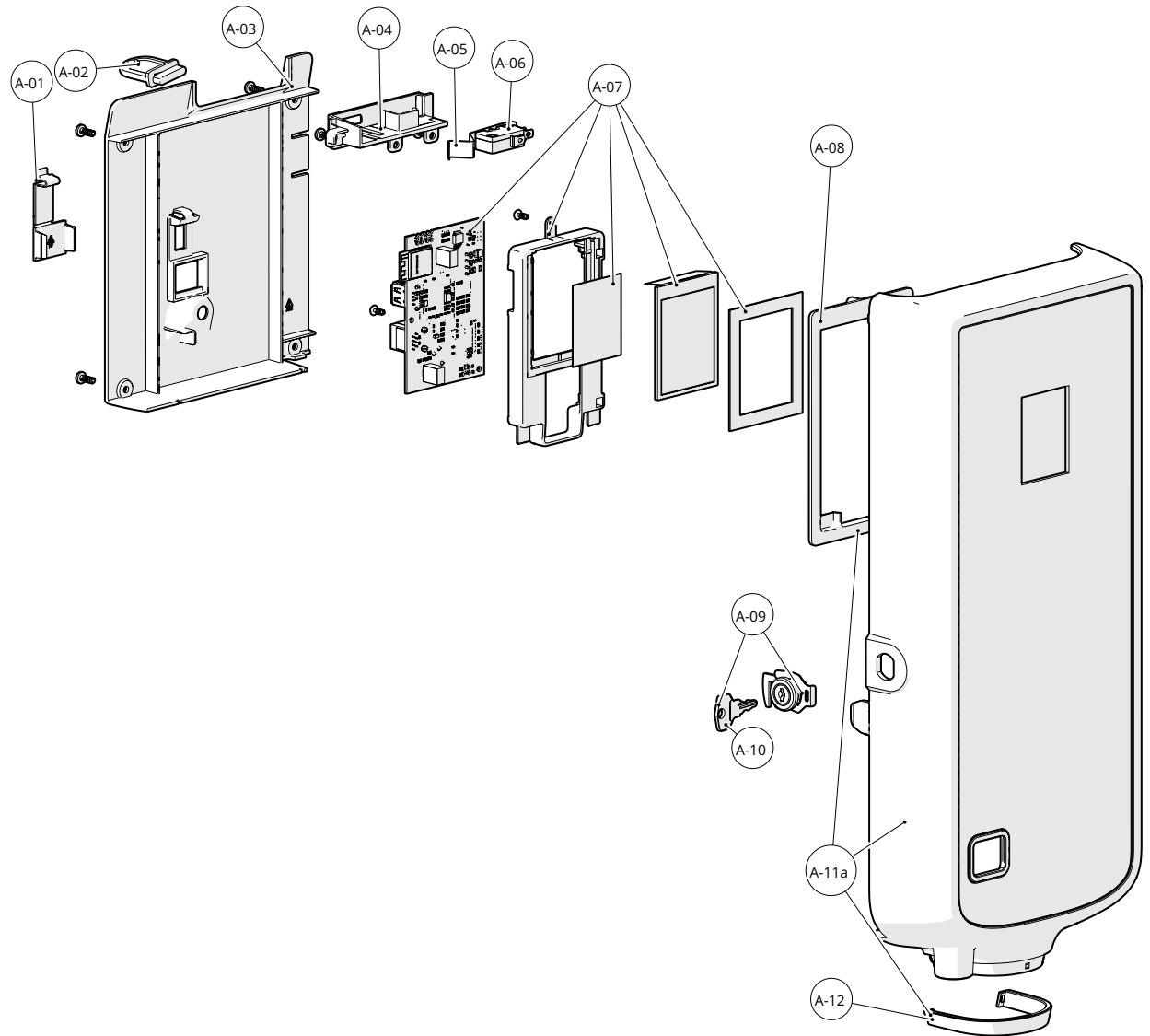
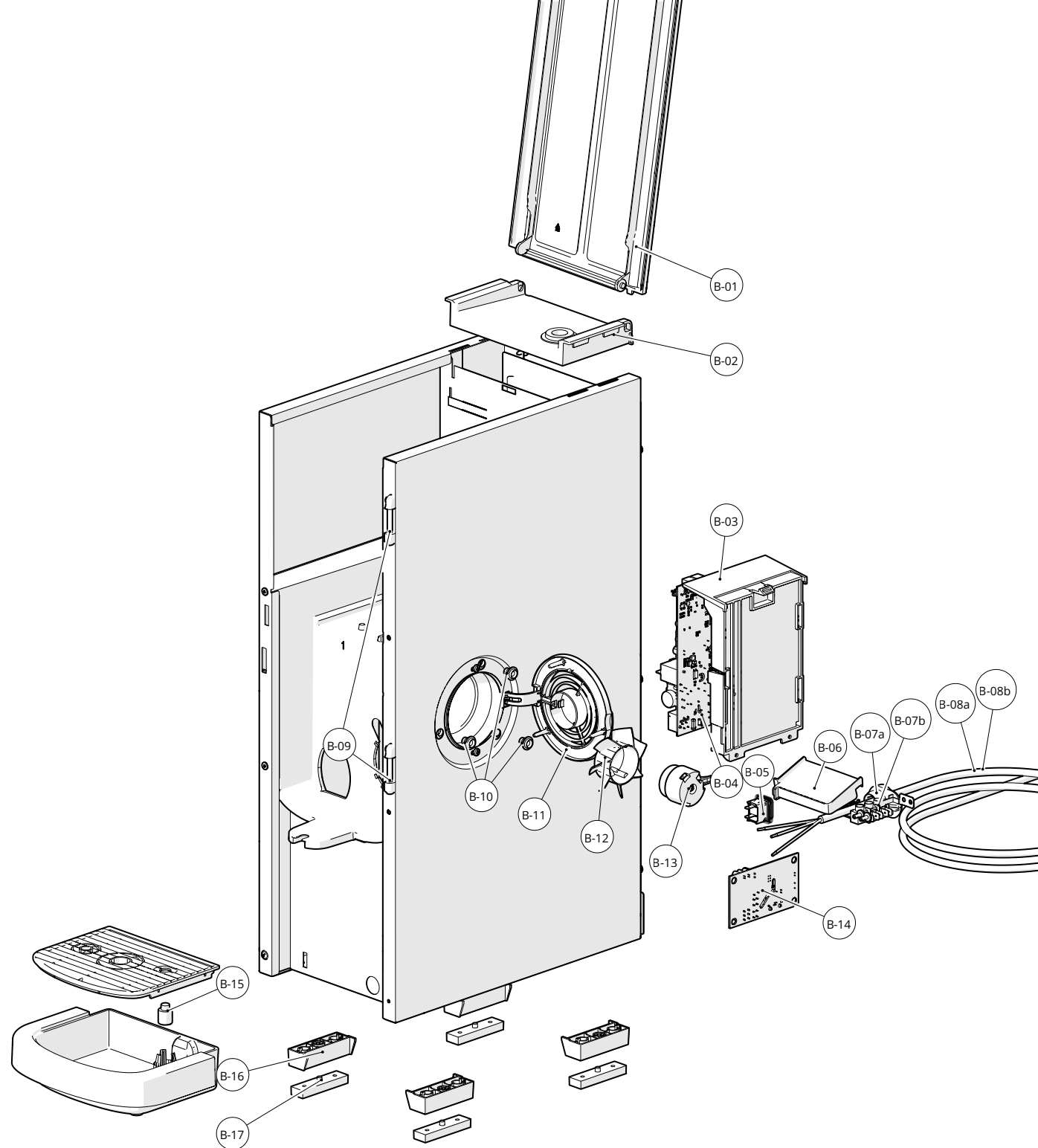

ID	Service parts	S-RS	Description
C-01	6.000.229.183	S	Canister 65mm (complete)
C-02	6.329.480.000	S	Lid 65mm
C-03	6.329.477.001	S	Drive shaft
C-04	6.329.478.001	S	Wiper
C-05	6.329.486.001	S	Axel
C-06	6.329.476.001	S	Canister casing
C-07	6.331.750.000	RS	Canister motor
C-08	6.030.074.006	S	Drive shaft
C-09	6.329.479.001	S	Seal
C-10	6.000.229.219	S	Worm (assy)
C-11	6.329.474.001	S	Canister bottom
C-12	6.229.274.001	S	Lid 134mm
C-13	6.329.503.001	S	Wiper
C-14	6.329.543.001	S	Adapter pice wiper
C-15	6.329.502.001	S	Axle canister 134 mm
C-16	6.329.500.001	S	Canister casing
C-17	6.000.229.197	S	Canister 134mm (complete)
C-18	6.329.248.000	S	Outlet canister central
C-19	6.329.088.000	S	Outlet canister left

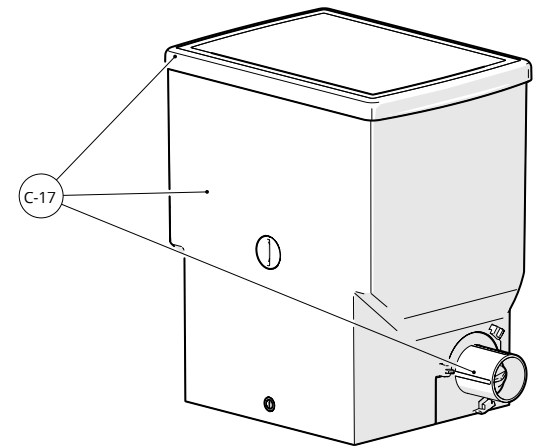
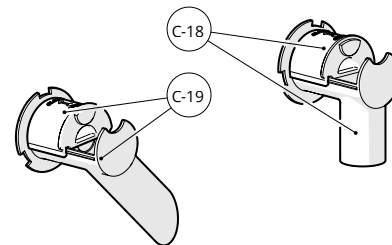
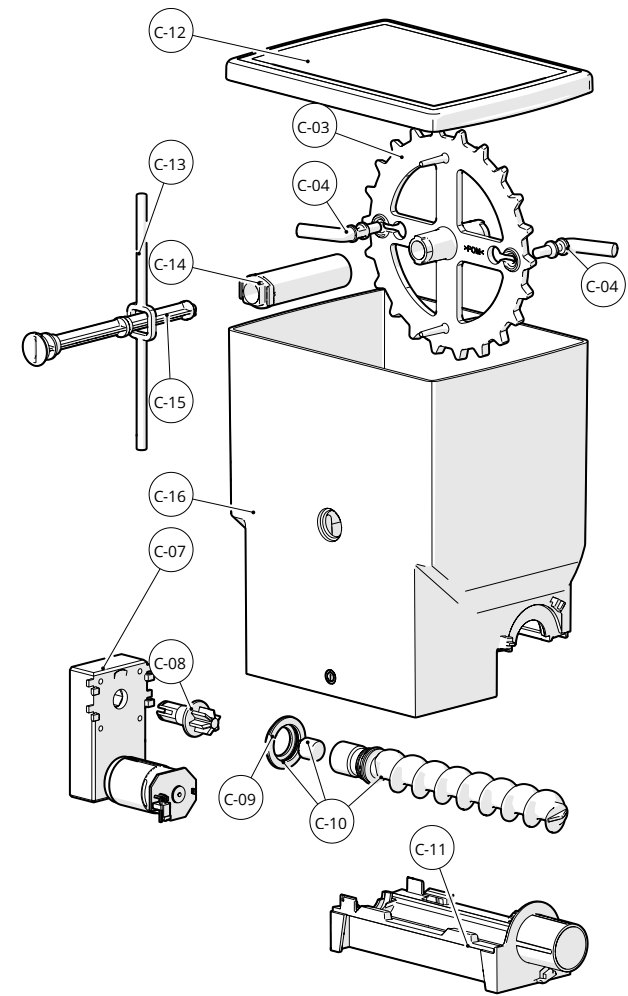
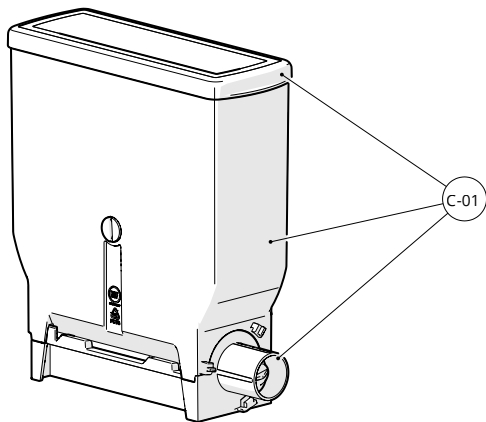
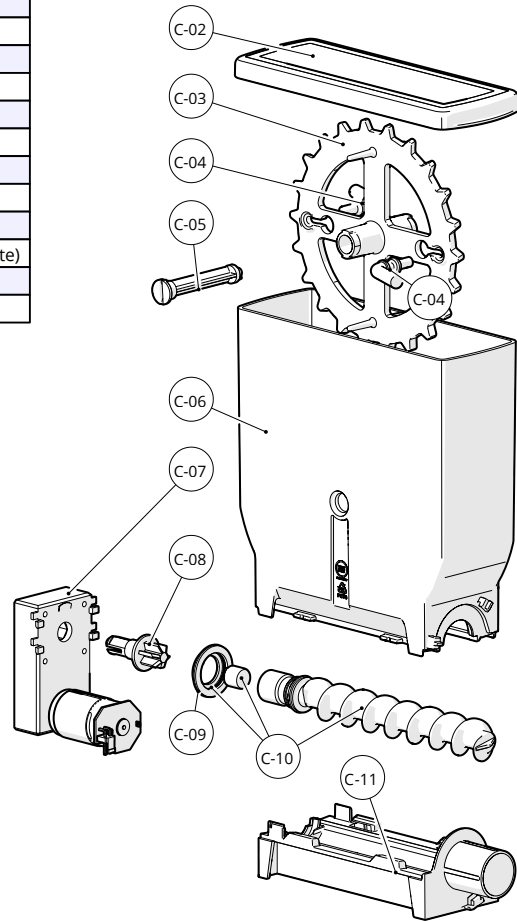

ID	Service parts	S-RS	Description
D-01	6.429.085.001	S	Condense reservoir
D-02	6.229.805.001	S	Mixing chamber
D-03	6.229.809.001	S	Fastening ring
D-04	6.229.803.001	S	Wiper disk
D-05	6.229.806.001	S	Rubber seal mixer
D-06	6.030.071.020	S	Rubber seal mixer
D-07	6.229.807.001	S	Holder rubber seal
D-08	6.229.810.001	S	Plate mixer motor
D-09	6.011.001.094	S	O-ring 13x2
D-10	6.030.070.022	S	Mixer motor
D-11	6.000.229.085	RS	Mixer motor (assy)
D-12	6.329.490.001	S	Mixing unit with outlet ø6
D-13	6.011.001.167	S	O-ring 8.5x1.5
D-14	6.329.491.001	S	Water inlet ø11.8

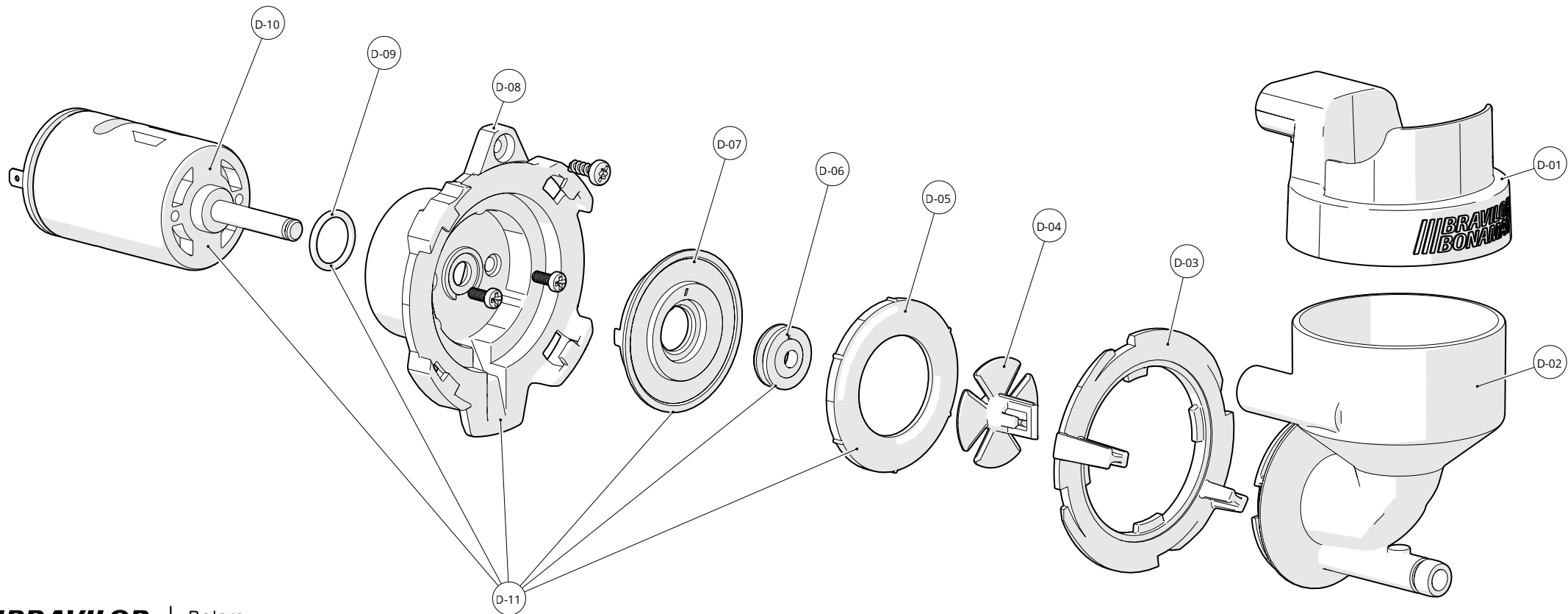
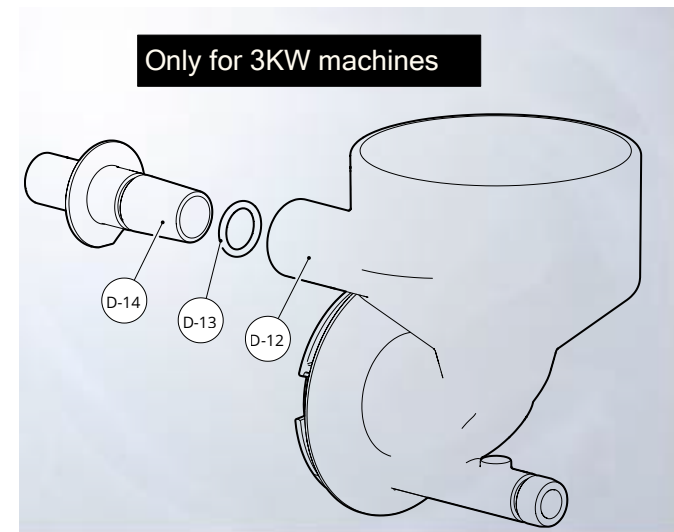

ID	Service parts	S-RS	Description	mm
E-01	6.016.001.070	RS	Magnetic valve 2 l/min 24V	
E-02	6.001.079.003	S	Tube clamp 15.6 mm	
E-03	6.019.033.014	S	Silicone tube 9.5x3.0	500
E-04	6.019.033.013	S	Silicone tube 11.5x3.0	430
E-05	6.231.132.001	S	T-coupling $\varnothing 16 \times \varnothing 16 \times \varnothing 8$	
E-06	6.001.079.001	S	Tube clamp 12.7 mm	
E-07	6.263.081.001	S	Drain hose	500
E-08	6.006.002.018	S	Tightening plug 10.5 mm	
E-09	6.429.201.001	S	Silicone tube with curve 80°	272
E-10	6.229.428.001	S	De-aeration pipe	
E-11	6.019.033.004	S	Silicone tube 7.5x2.0	420
E-12	6.229.580.001	S	Water inlet 6mm	
E-13	6.011.001.152	S	O-ring 6.02x1.63	
E-14	6.429.063.001	S	Outlet	
E-15	6.019.033.009	S	Silicone tube 7 x 4	100
E-16	6.402.010.001	S	Descaler cover	
E-17	6.236.353.001	DT	Overflow hose	420
E-18	6.229.760.001	S	Nipple	

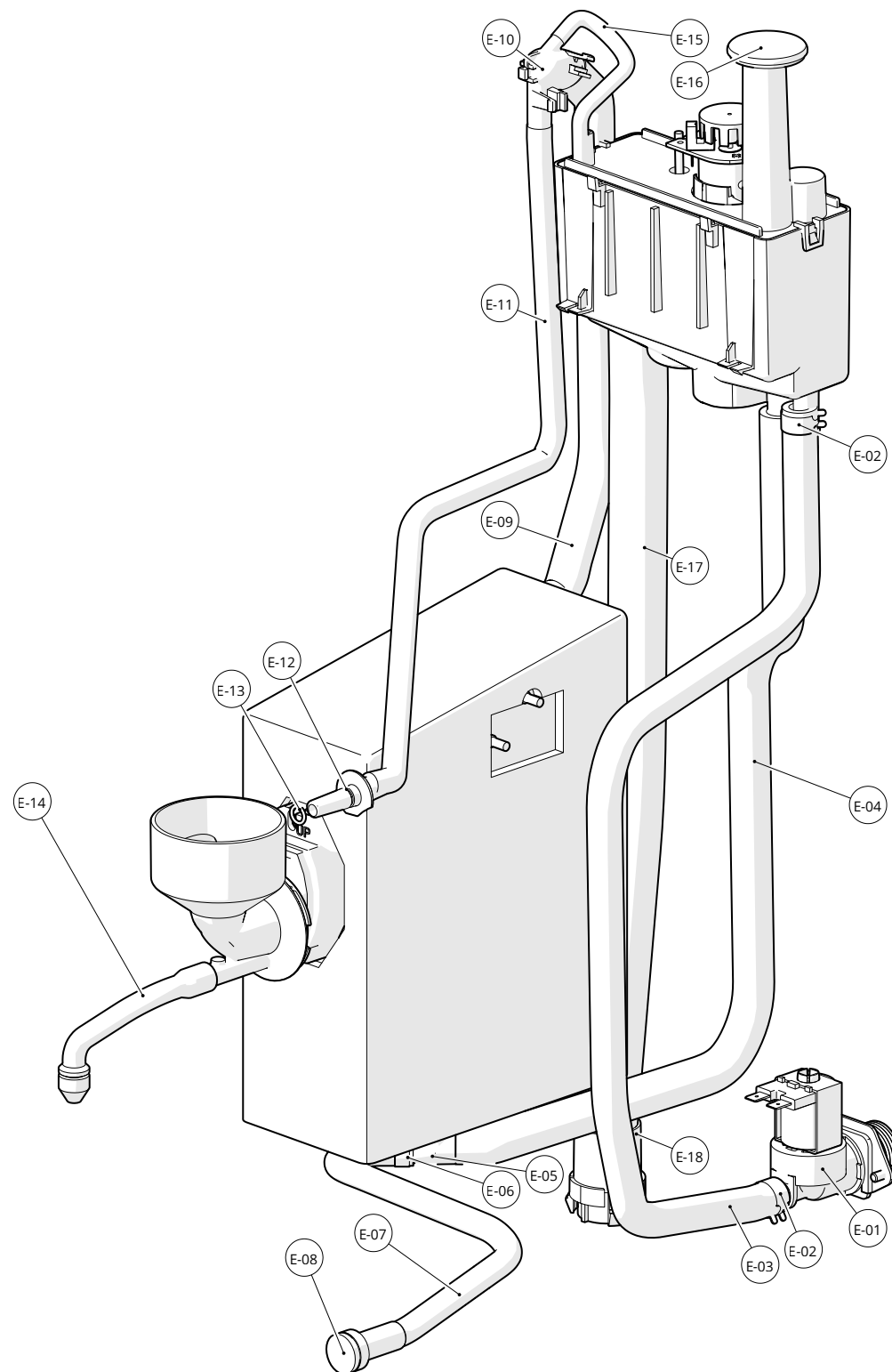

ID	Service parts	S-RS	Description
F-01	6.229.594.001	S	Positioning wheel
F-02	6.229.334.001	S	Lid pumpfloat tank
F-03	6.229.891.001	S	Float
F-04	6.000.229.198	RS	Pump float tank 4000 rpm
F-05	6.229.335.001	S	Pumpfloat tank

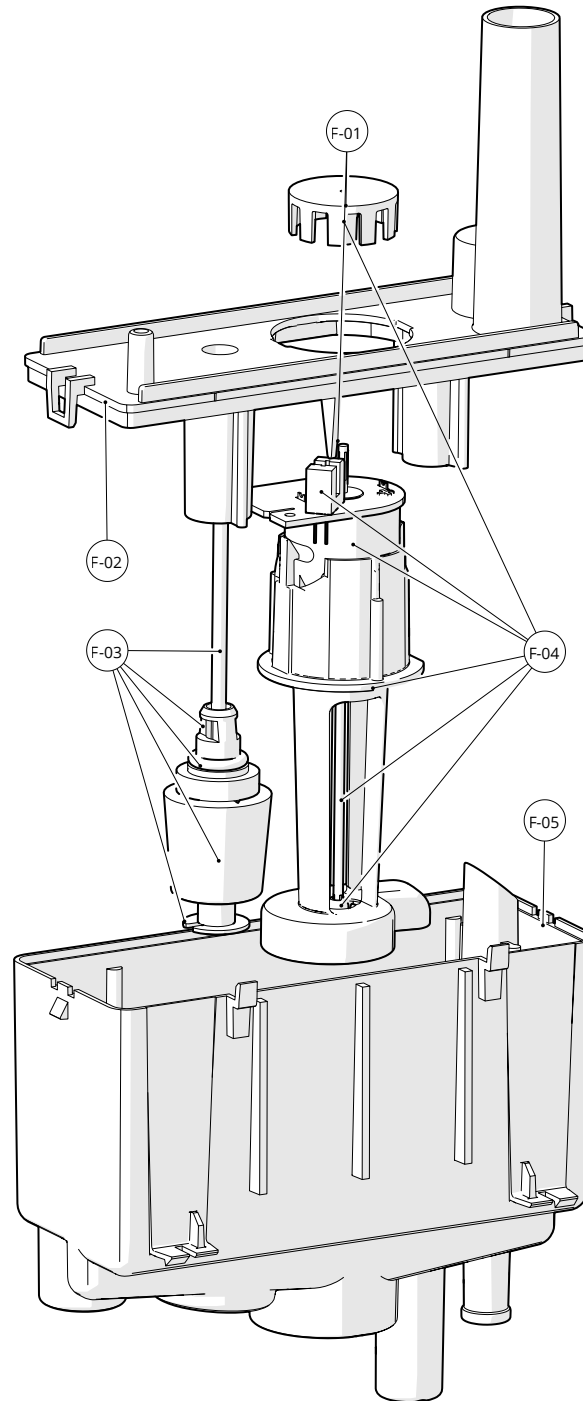

ID	Service parts	S-RS	Description
G-01	6.429.166.000	S	Tap Bolero 1/2 complete
G-02	6.429.061.001	S	Tap handle
G-03	6.329.195.001	S	Cover tap housing
G-04	6.329.197.001	S	Leverrod tap
G-05	6.015.001.215	RS	Compression spring for tap
G-06	6.015.001.213	RS	Rubber cup
G-07	6.429.098.001	S	Tap housing
G-08	6.329.262.001	S	Tightening plug
G-09	6.231.191.001	S	Silicone ring
G-10	6.231.132.001	S	T-coupling $\varnothing 16 \times \varnothing 16 \times \varnothing 8$
G-11	6.016.008.084	RS	High temp safety switch
G-12	6.016.008.078	DT	Hook
G-13	6.331.485.000	RS	Temperature sensor (assy)
G-14	6.000.229.133	RS	Flow boiler 230V 2100W
G-15	6.000.229.134	RS	Flow boiler 3kW

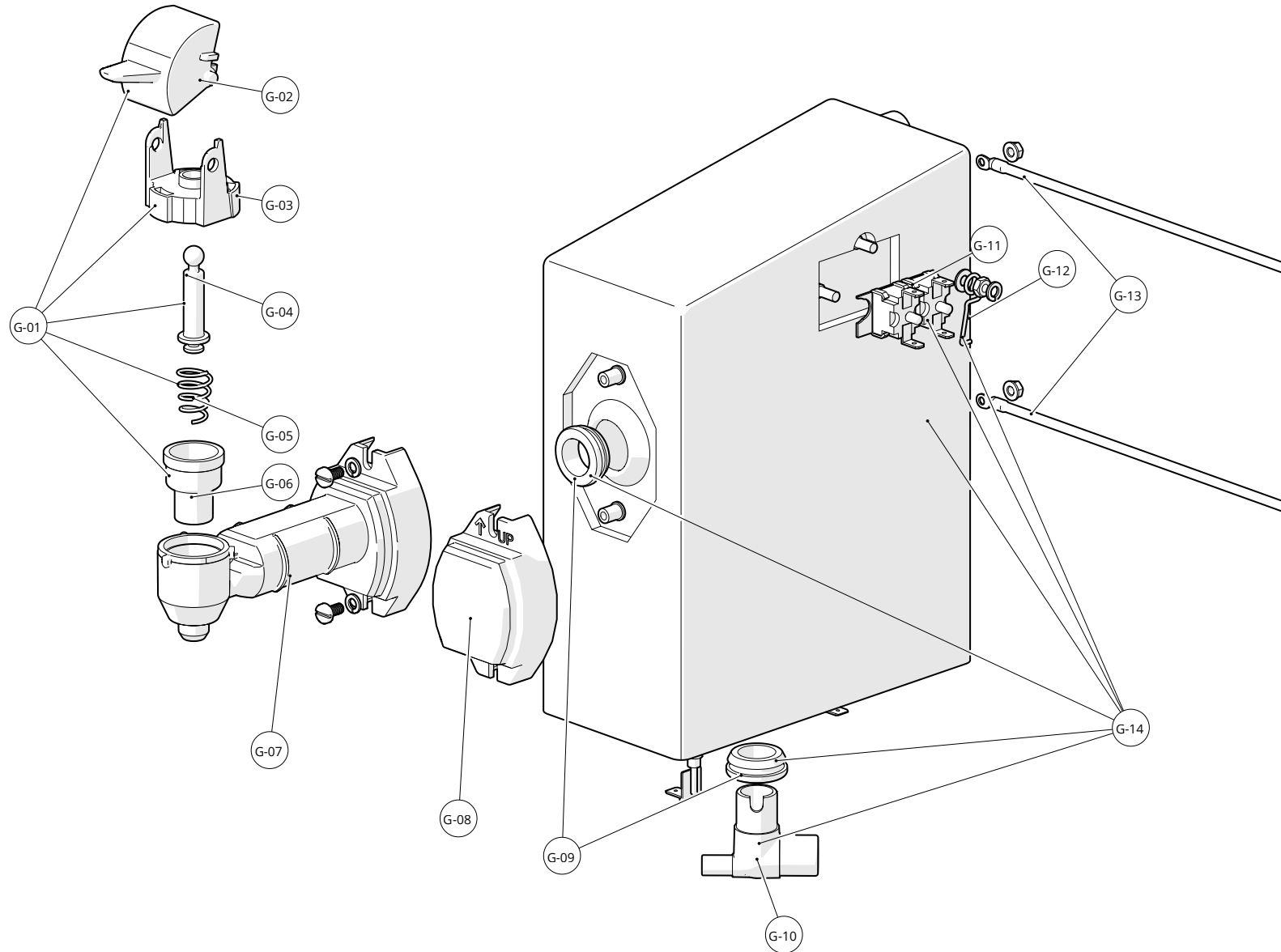
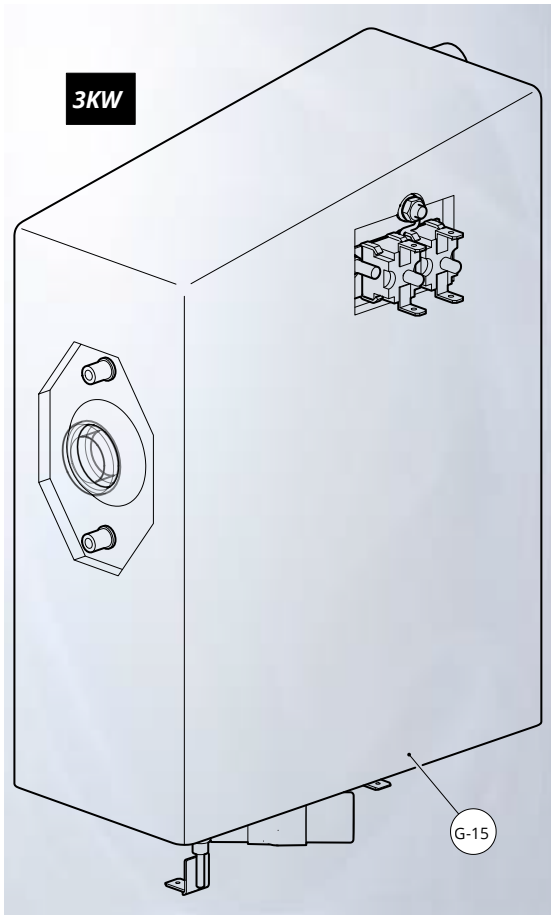

# Hygiene kits

Bolero 1 / 2

